

2 INCH DOWNLIGHT

INSTALLATION INSTRUCTIONS



WARNING:

- This product must be installed in accordance with the applicable installation code by a person familiar with the construction and operation of the product and the hazards involved.
- Make sure all electrical power is turned off while installing the fixture.
- This luminaire must be adequately grounded for protection against shock hazards and to assure proper operation.
- Disconnect power before servicing.
- LEDs are ESD (Electro Static Discharge) sensitive devices that can be easily damaged if the proper ESD mitigating steps are not taken.
- LEDs are very sensitive to mechanical damage. Caution must be taken to avoid damage to the LEDs.
- ESD or mechanical damage voids all warranties.

FOR USE WITH:

- 2AR ▪ 2AS ▪ 2DR ▪ 2DS

TABLE OF CONTENTS

MOUNTING PAN INSTALLATION.....	1	DOWNLIGHT INSERT INSTALLATION.....	3
ELECTRICAL CONNECTIONS.....	2	SWING OUT ARMS/MOUNTING CLIPS INSTALLATION.....	4
JUNCTION BOX INSTALLATION.....	2	UNIVERSAL TILT AND ROTATION ADJUSTMENT.....	5
OPTIONAL REGRESSED TEST SWITCH INSTALLATION.....	3	TRIM INSTALLATION.....	5

MOUNTING PAN INSTALLATION (For remodel, proceed to STEP 4 ON PAGE 2)

NOTE: Top access required: (2DR, 2DS) N Mounting Type when specified with EM battery; (2AR, 2AS) N and I Mounting Types.

STEP 1: Pre-attach the specified mounting hardware to the fixture pan. See FIG 1.1 – FIG 1.4

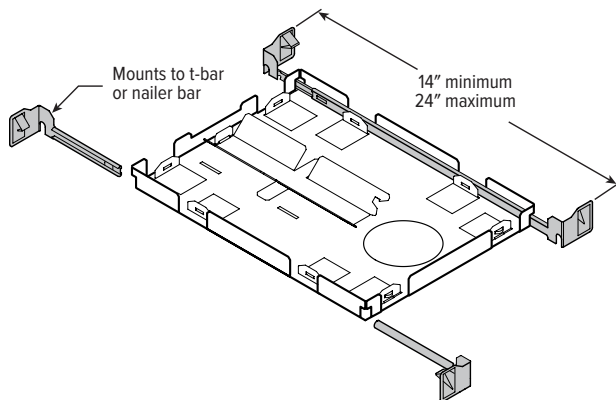

FIG 1.1 F1 Integral 2-position fixed pan bracket.

FIG 1.2 F1 with I Mounting Type

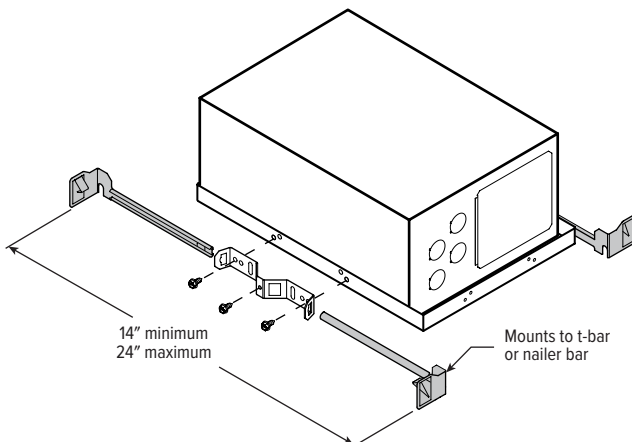

FIG 1.3 BA1 Butterfly bracket only | BA2 Heavy-duty universal bar hanger, shown

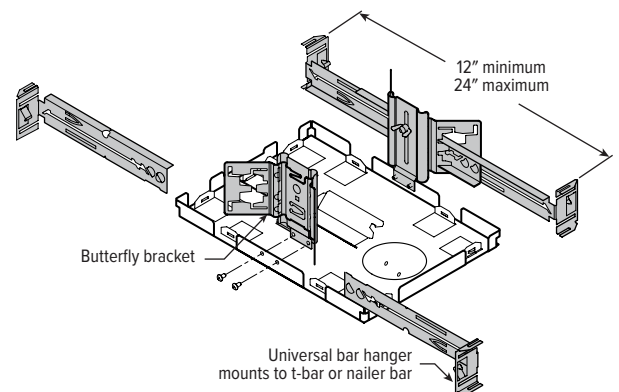
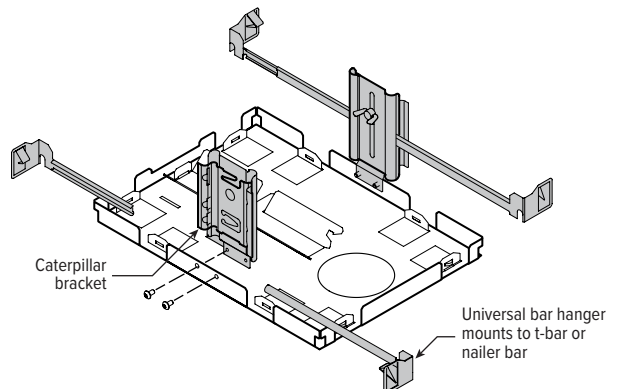

FIG 1.4 Adjustable caterpillar pan bracket
CA1: Universal bar hanger, shown: 14" min – 24" max
CA2: T-bar clip hanger: 11" min – 26" max



STEP 2: Install pan assembly as required for ceiling structure while aligning the pan aperture with the ceiling cutout.

STEP 3: Route the flexible metal conduit containing all of the required power input and control leads to the pan location. Leave enough length for pulling at least one foot below the ceiling plane through the ceiling cutout.

2 INCH DOWNLIGHT

INSTALLATION INSTRUCTIONS

ELECTRICAL CONNECTIONS

STEP 4: Connect junction box to conduit

- A. Pull the flexible conduit down through the ceiling cutout and connect the junction box, see FIG 4.1

FOR IC MOUNTING ONLY: Route supply conduit to the IC housing knockout and connect to the IC housing, see FIG 4.2

FIG 4.1 NEW CONSTRUCTION | REMODEL

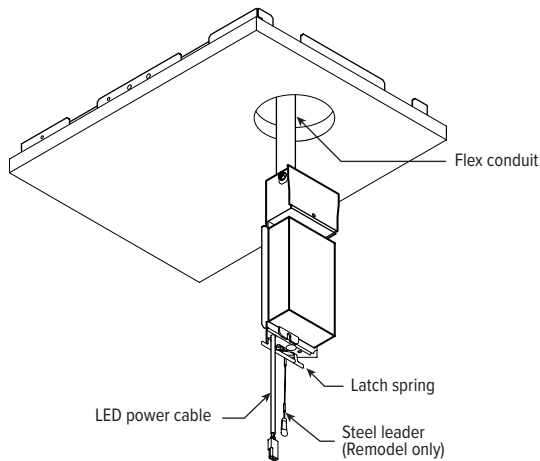
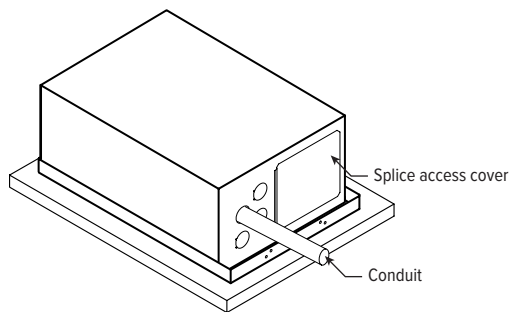
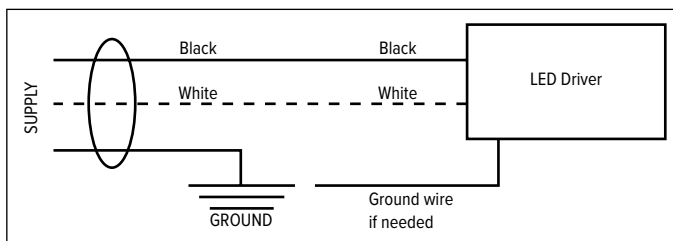

FIG 4.2 IC MOUNTING



- B. Make all necessary lead terminations within the junction box. Attach power supply and ground wires using UL listed wire connectors. Ballast disconnect accepts #12 - #16 AWG stranded or solid wire. Re-attach the access cover. Please consult factory for other driver configurations or emergency driver wiring diagrams.



JUNCTION BOX INSTALLATION

STEP 5: Install junction box

- A. FOR NEW CONSTRUCTION ONLY: Install junction box to mounting pan (see FIG 5.1) Maneuver the junction box up through the ceiling cutout, rotate down 90°, then slide back into the receiver bracket until the latch spring engages to lock it into the pan.

FOR REMODEL ONLY: Install junction box in ceiling plenum. (see FIG 5.2) Maneuver the junction box up through the ceiling cutout, place 2" from ceiling opening.

FIG 5.1 NEW CONSTRUCTION

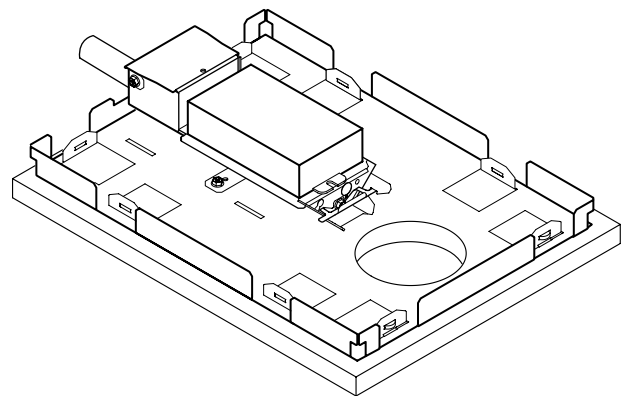

Note: LED power cable and steel leader (Remodel only) were removed for clarity

FIG 5.2 REMODEL

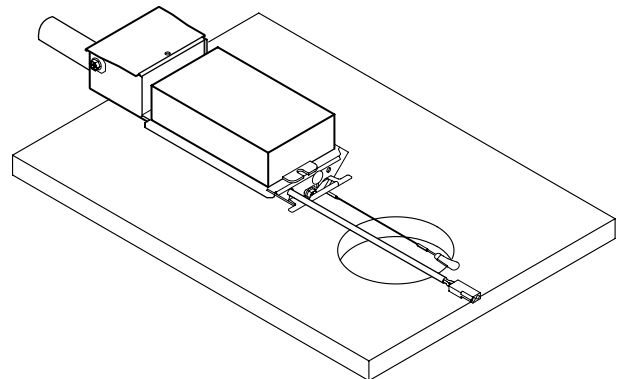

- B. Pull the LED power cable and steel leader (Remodel only) down through the ceiling cutout so they are accessible for the downlight insert installation.

2 INCH DOWNLIGHT

INSTALLATION INSTRUCTIONS

OPTIONAL REGRESSED TEST SWITCH INSTALLATION

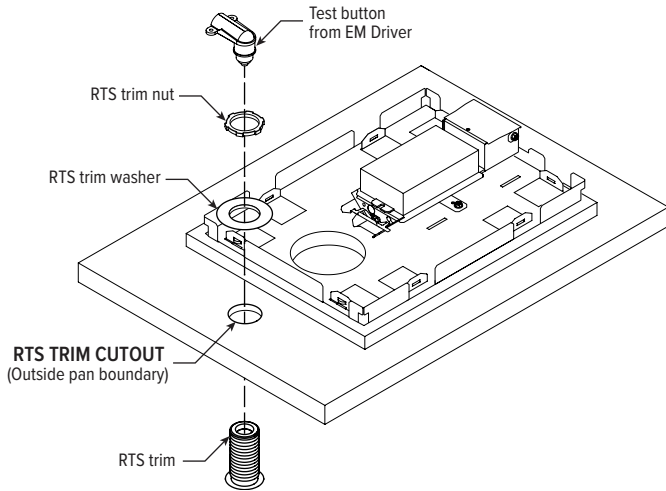

NOTE: Top access required for installation. The RTS trim, nut and washer will be supplied as a kit that ships with each EM/10W/RTS specified downlight.

- Using a 1-3/8" hole saw, measure and drill the RTS trim cutout so that it is **located outside the pan boundary**
- Push the RTS trim up through the RTS trim cutout, then hold it against the ceiling
- Install the RTS washer and RTS nut to the RTS trim, leaving loose
- Maneuver the test button onto the RTS trim. Rotate the RTS trim from below to secure it to the test button
- To complete installation, tighten the RTS nut firmly against the RTS washer

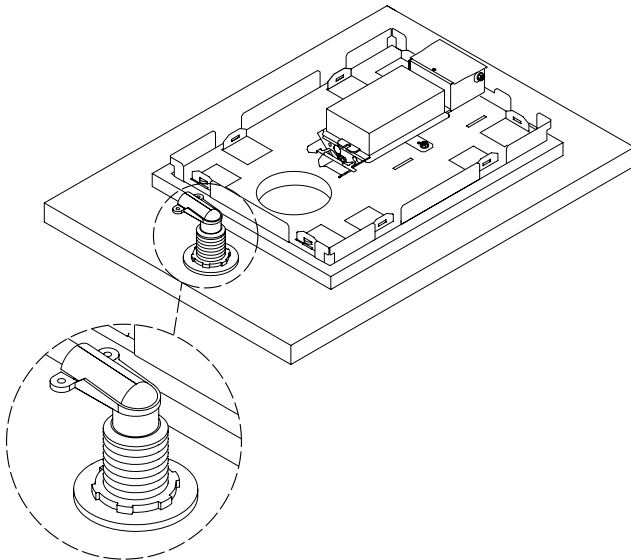

DOWNLIGHT INSERT INSTALLATION

STEP 6: Connect downlight insert to power (see FIG 6.1)

- REMODEL ONLY:** Connect the steel leader to the wire lanyard so the downlight insert is supported. The fixture will need to remain supported for remodel installations.
- Terminate the LED power cable to the LED input cable on the downlight insert.

FIG 6.1

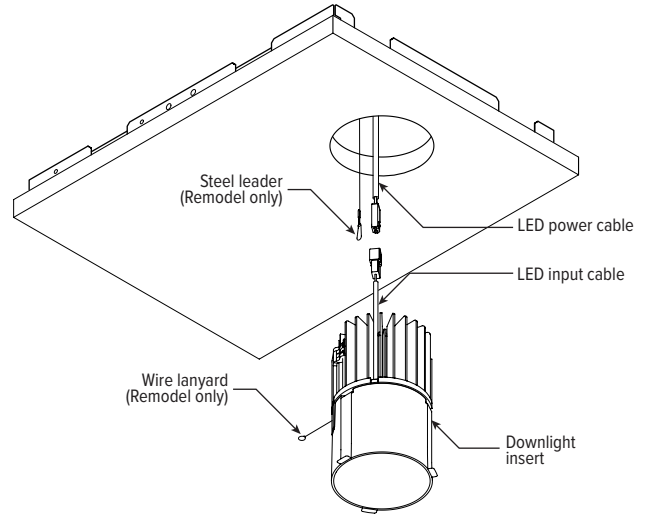

Downlight insert (bottom view)

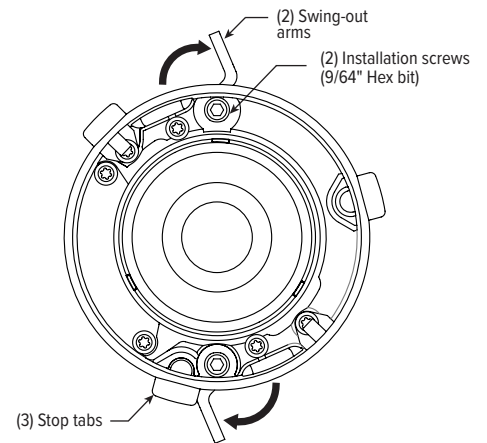

C. Install downlight insert to ceiling

Maneuver the downlight insert up through the ceiling cutout until the stop tabs are flush against the ceiling plane.

2 INCH DOWNLIGHT

INSTALLATION INSTRUCTIONS

SWING OUT ARMS/MOUNTING CLIPS INSTALLATION

STEP 7: Secure downlight

NOTE: If job-related ceiling thickness is outside of specified ranges, please consult factory.

SWING OUT ARMS ONLY: 2DR, 2DS (see FIG 7.1):

While continuing to support the insert, use a 7/64" hex bit to drive the installation screws - this will cause the swing-out arms to deploy, draw down, and clamp the insert in place.

Ceiling thickness range: 1/2" – 1-9/16"
(standard, see below for thick ceiling modification)

FIG 7.1 SWING OUT ARMS. New construction shown. Remodel has no pan.

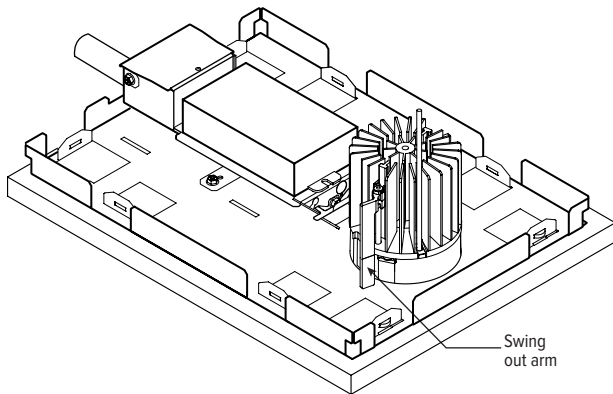

THICK CEILING MODIFICATION

2DR and 2DS fixtures are easily field modified for thick ceiling applications. As shipped they are configured to a ceiling thickness range of 1/2" to 1-9/16". They are engineered to be field modified as needed to accommodate thick ceilings from 1-1/2" to 2-3/8" thick.

Using (2) pairs of pliers, firmly grasp swing out arm above and below engineered fracture point and bend short side as shown to shorten (see FIG 7.2)

FIG 7.2 2DR | 2DS thick ceiling modification

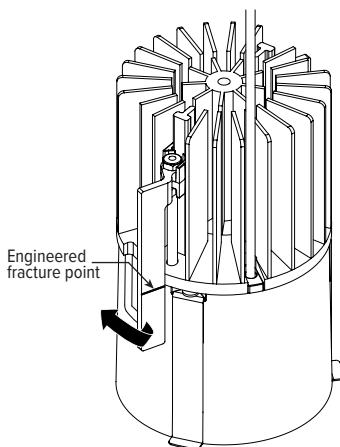

MOUNTING CLIPS ONLY: 2AR, 2AS (see FIG 7.4):

While continuing to support the downlight insert, install mounting clips through the trim housing slots to engage the ceiling/pan/IC housing, (2) clips for round, (4) clips for square. Locate each clip's notch and use the corner of a flathead screw driver to push the clips into place.

Ceiling thickness range: 1/2" – 13/16" (clip # 81013134)

FIG 7.3 MOUNTING CLIP SLOT LOCATION

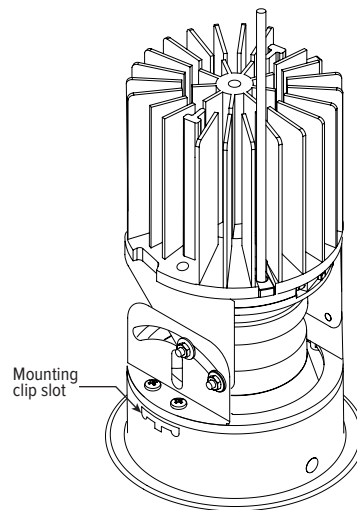
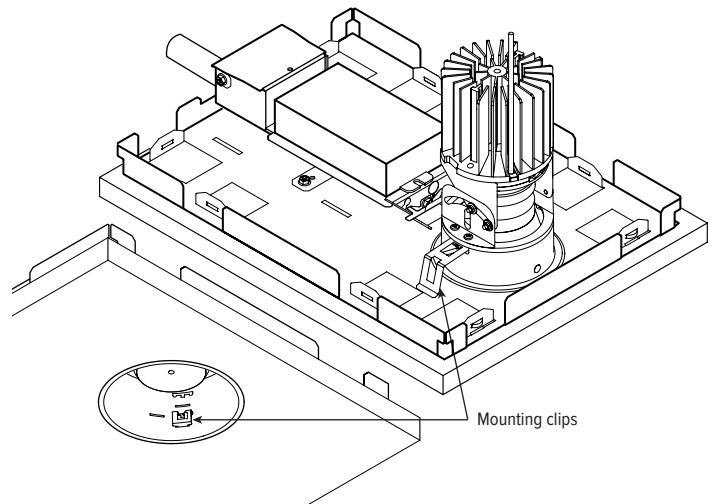

FIG 7.4 MOUNTING CLIP. New construction shown. Remodel has no pan.



2 INCH DOWNLIGHT

INSTALLATION INSTRUCTIONS

UNIVERSAL TILT AND ROTATION ADJUSTMENT

FOR USE WITH 2AR, 2AS

Adjust fixture aiming angles

- Loosen the (2) rotation angle adjustment screws using 3/32" hex wrench and rotate optical assembly to desired direction. (see FIG 7.5)
- Rotate tilt adjustment screw to aim beam to achieve desired effect. (see FIG 7.5 – FIG 7.6)
- Fine tune both adjustments then tighten rotation angle adjustment screws.

NOTE: Tilt angle indicator visible inside throat of fixture (see FIG 7.7)

FIG 7.5

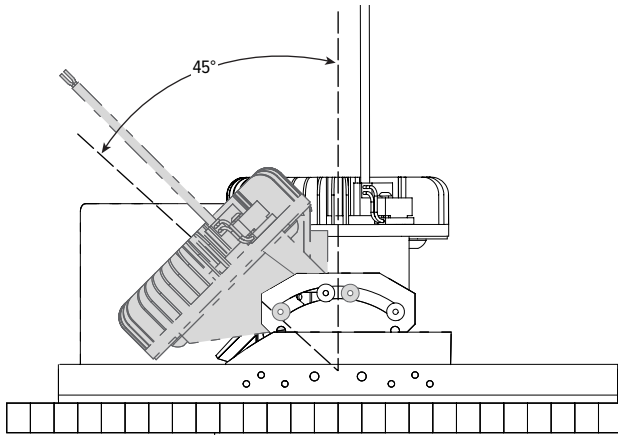

FIG 7.6

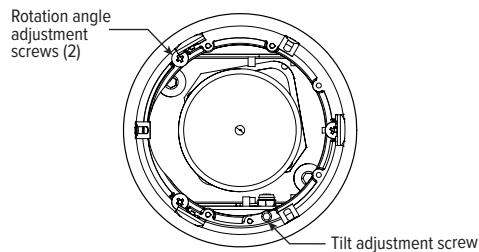
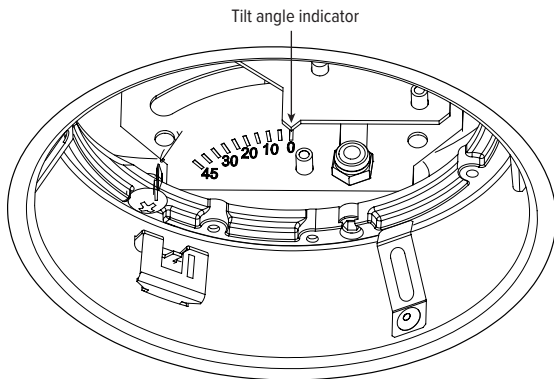

FIG 7.7



TRIM INSTALLATION

STEP 8: Install trim

ADJUSTABLE REFLECTOR INSTALLATION FIG 8.1

FOR USE WITH 2AR & 2AS

- Align beam clearance notch with fixture optic.
- Insert reflector assembly into fixture until flush with ceiling to engage retention springs

FIG 8.1

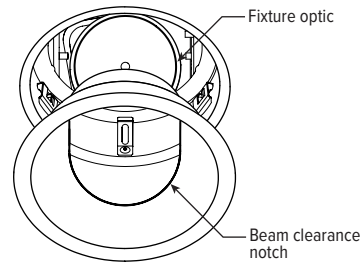

RETENTION SPRING REFLECTOR INSTALLATION See FIG 8.2

FOR USE WITH 2DR, 2DS, 2AR, 2AS

- Insert reflector assembly into fixture until flush with ceiling to engage retention springs

FIG 8.2

